

Product Model

POW-M25-PRO

POW-M35-PRO

POW-M45-PRO

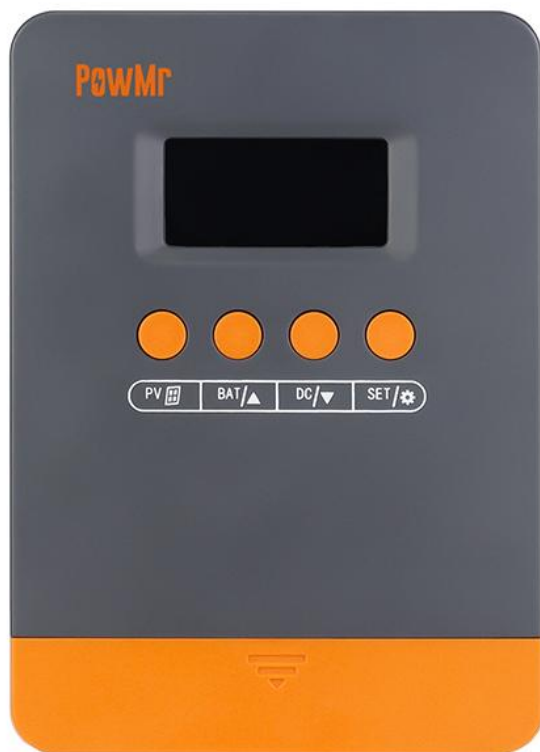

# POWMr

SOLAR CHARGE CONTROLLER

User Manual

---

## **Important Safety Guidelines**

---

Warning: Please carefully read and adhere to all safety instructions.

- Before installing and operating the controller, carefully read the user manual and keep it stored safely for future reference.
- Installation or operation of the controller is not permitted for the following individuals without strict guidance and supervision:
  - a. Anyone lacking the relevant knowledge, experience, or capability for safe installation and/or operation requirements.
  - b. Anyone with impaired or diminished physical, sensory, or intellectual capabilities that may affect safe installation and/or operation (including children).

### **Controller Installation and Operation**

- a. This controller product has no user-serviceable parts. Do not dismantle or attempt to repair the controller.
- b. Install the controller in an environment with good natural ventilation and ensure sufficient spacing around it.
- c. Mount the controller on a non-flammable wall and ensure there are no flammable materials nearby; temperature elevation during controller operation is normal.
- d. Install the controller in an environment free from direct sunlight, rainwater, humidity, and dust, and keep it away from any flammable liquids or gases. The controller is for indoor use only.
- e. Do not install or place/operate the controller on top of or directly above batteries or in enclosed spaces containing batteries, as batteries release explosive gases.
- f. Do not place any other items on top of the controller.

### **Battery Installation and Charging**

- a. Install and charge batteries in a well-ventilated or exhaust environment.
- b. Ensure there are no sources of ignition around the batteries, as they release explosive gases.
- c. Battery acid is corrosive; if battery acid comes into contact with the skin, immediately rinse with clean water.
- d. Do not charge non-rechargeable batteries. Do not charge lithium batteries when the temperature is below 0°C. Charging frozen batteries is prohibited.

- e. Ensure the equipment is set up reasonably according to the connected battery type.

## DC Battery Wiring

- a. Ensure all cables and/or new ports connecting to the battery/DC system are fully closed/disconnected in advance.
- b. Use flexible multi-strand copper cables with appropriate cross-sectional areas and connect them to matching fuses or circuit breakers.
- c. It is prohibited to connect the solar array to the controller without the battery connected; priority must be given to connecting the battery.

## Controller Settings

- a. Refer to the battery manufacturer's guide and specifications to ensure the batteries are suitable for the controller and confirm the recommended charging settings.
- b. Integrated charging modes include adaptive charging logic, which is suitable for most battery types.

## Disclaimer

**In any of the following circumstances, our company reserves the right to disclaim liability for quality assurance:**

- Damage caused by improper transportation.
- Damage resulting from incorrect storage, installation, or usage.
- Damage caused by non-professionals or untrained personnel installing and using the equipment.
- Damage resulting from failure to adhere to the instructions and safety warnings in this document.
- Damage caused by operation in environments not meeting the requirements specified in this document.
- Damage resulting from operation beyond the parameters specified in the applicable technical specifications.
- Damage caused by unauthorized dismantling, alteration of the product, or modification of software code.
- Damage caused by exceptional natural circumstances (force majeure), such as lightning, earthquakes, fires, storms, etc.
- Any damage resulting from failure to follow local standards and regulations during installation and operation processes.
- Products beyond the warranty period.

## Table of Contents

Important Safety Guidelines .....	1
1 Product Introduction .....	4
1.1 Features .....	5
1.2 Product Appearance .....	7
2 Installation and Wiring .....	8
2.1 Unboxing and Inspection .....	8
2.2 Selecting Installation Location .....	8
2.3 Wiring Precautions .....	9
2.4 Installation and Wiring Guide .....	9
3 Operation Guide .....	12
3.1 Button Introduction .....	12
3.2 Key Introduction .....	13
3.3 Operation Mode Description .....	14
3.4 Overview of PV Parameters .....	14
3.5 Battery Parameters Overview .....	15
3.6 Battery Parameter Settings .....	16
3.7 Default Parameters for Different Battery Types .....	19
3.8 Load Operation Mode Settings .....	21
4 Protection .....	22
4.1 Protection Functions .....	22
4.2 Troubleshooting .....	23
5 Maintenance .....	24
6 Specification Parameters .....	25

## 1 Product Introduction

Welcome to the POW-M series solar controllers, a forefront innovation in solar technology designed to provide exceptional performance and reliability for your solar system. Our meticulously designed controllers incorporate advanced digital control technology, featuring an LCD screen and user-friendly buttons to enhance configuration flexibility, allowing real-time monitoring of operational data and system status. Additionally, the controllers support Maximum Power Point Tracking (MPPT) battery charging mode, maximizing energy utilization efficiency.

The POW-M series solar controllers are engineered to meet diverse solar system requirements, whether in standalone systems or other application scenarios. They automatically control the battery charging and discharging processes, optimizing these operations to extend battery life and improve overall system performance. Equipped with self-detection and electronic protection functions, the controllers effectively prevent damage during installation errors or system malfunctions, ensuring system reliability and stability.

Our POW-M series solar controllers offer extensive expandability and customization options, streamlining the solar system configuration process. Whether you are building a standalone solar system or expanding a solar energy project, the POW-M series controllers will be an indispensable partner. Their compact size and lightweight design, combined with air-cooled and aluminum alloy backplate natural cooling technologies, enhance operational safety, stability, and suitability for various scenarios. The parallel function allows users to easily scale up their solar energy capacity.

The POW-M series solar controllers are available in 25A, 35A, and 45A charging current options, ensuring your solar system can efficiently capture and store energy. Whether you are seeking an efficient, sustainable, and secure energy management solution or providing robust support for future energy demands, the POW-M series solar controllers are your ideal choice. We are committed to advancing solar technology, offering you exceptional products and services to support your solar system construction.

## 1.1 Features

- **Integrated Charging Presets**

The integrated charging modes include adaptive charging logic, making them suitable for most battery types, such as flooded lead-acid, sealed gel, and lithium batteries. Specific charging parameters for each battery type can be found in section 3.7.

- **Flexible Application**

Compatible with 12V/24V system voltages.

- **25A/35A/45A Charging Controllers**

Available in 25A, 35A, and 45A charging current options to meet the needs of various solar energy storage systems.

- **Multi-Stage Charging Algorithm**

The multi-stage charging algorithm is designed to optimize each charging cycle, maintaining battery charge through preset charging parameters for specific stages once the battery is fully charged.

- **Maximum Power Point Tracking Technology**

MPPT technology tracks the maximum power point voltage ( $V_{mp}$ ) of the array, which varies with weather conditions, ensuring maximum power is collected from the array throughout the day.

- **Efficient Charging**

Innovative MPPT technology with tracking efficiency up to 99.9% and peak conversion efficiency up to 97%, reducing power consumption, heat generation, and operating temperature.

- **Adaptive Boost Charging**

During initial charging, adaptive boost charging monitors the battery's response and automatically determines the appropriate boost stage duration for each independent charging cycle. This ensures the battery is fully charged at any discharge level or capacity, avoiding overcharging during the boost stage, thereby extending battery life.

- **Durable and Safe**

- Overcurrent protection for PV input
- PV array short circuit protection
- PV reverse polarity protection
- Battery overvoltage protection
- Battery over-discharge protection
- Over-temperature protection

- **Accurate Battery Temperature Monitoring**

When the battery temperature exceeds 80°C, temperature compensation is automatically performed, reducing charging power to protect the battery.

- **Lithium Battery Activation**

Compatible with lithium batteries, the charging cycle will adapt when the battery type parameter is set to lithium. If the connected lithium battery is in protection mode, the controller will activate the lithium battery using energy from the solar panels, with current not exceeding the lithium battery protection voltage and protection current range.

**Warning:** Do not charge lithium batteries when their temperature is below 0°C.

## 1.2 Product Appearance



1	LCD Display	5	Load Interface
2	Function Buttons	6	Port Cover
3	PV Input Interface	7	Heat Sink
4	Battery Interface	8	Mounting Holes

## 2 Installation and Wiring

### 2.1 Unboxing and Inspection

Before unboxing, check if the packaging is damaged. After unboxing, inspect the contents for any damage or missing items. Inside the package, you will find:

- Controller
- User Manual
- Dedicated Mounting Screws
- Installation Guide Card

### 2.2 Selecting Installation Location

Before installation, consider the following aspects to determine/provide a suitable and safe installation location:



Install the controller in a space with good natural ventilation/exhaust.



Avoid direct sunlight.



Ensure there is sufficient clearance around the controller. The minimum clearance for the top, bottom, and sides of the controller is 75mm.



Mount the controller on a non-flammable wall and ensure there are no flammable materials nearby; temperature elevation during controller operation is normal.



Install the controller in an environment free from direct sunlight, rainwater, humidity, and dust, and keep it away from any flammable liquids or gases. The controller is for indoor use only.



Do not install or place/operate the controller on top of the battery, directly above it, or in an enclosed space where the battery is located, as the battery may release explosive gases.

## 2.3 Wiring Precautions

1. Installation and wiring should be carried out by a certified electrician.
2. Follow this sequence when wiring: Battery > PV Input > DC Output.
3. To avoid short circuits and reverse polarity, ensure that the positive (+) cable is connected to the positive (+) terminal of the equipment and the negative (-) cable to the negative (-) terminal.
4. Undersized or loose connections can cause cables or terminals to overheat. Therefore, tighten all cables to minimize transitional resistance. Use cables of appropriate size according to the current of the specific circuit.

## 2.4 Installation and Wiring Guide

- Step 1.** Install the controller vertically with the ports facing downward. Secure it to the wall using screws through the four mounting holes on the body. For easier installation, it is recommended to "hang" the equipment using the two upper screws first, then add the two lower screws, and finally secure all four screws completely.

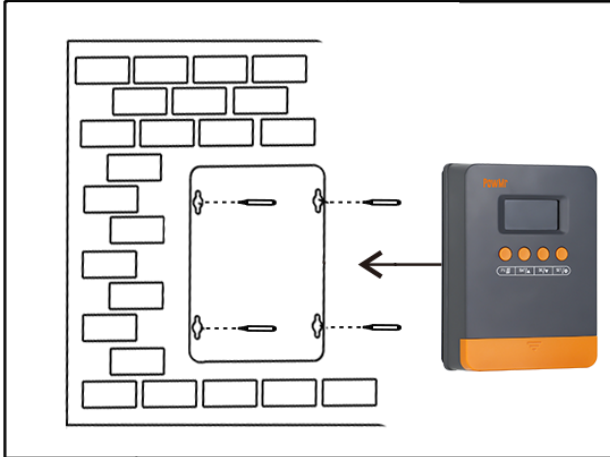

**Step 2. Battery wiring:** Connect the battery to the controller using cables.

**NOTICE**

- If an inverter needs to be connected, please refer to the diagram below.

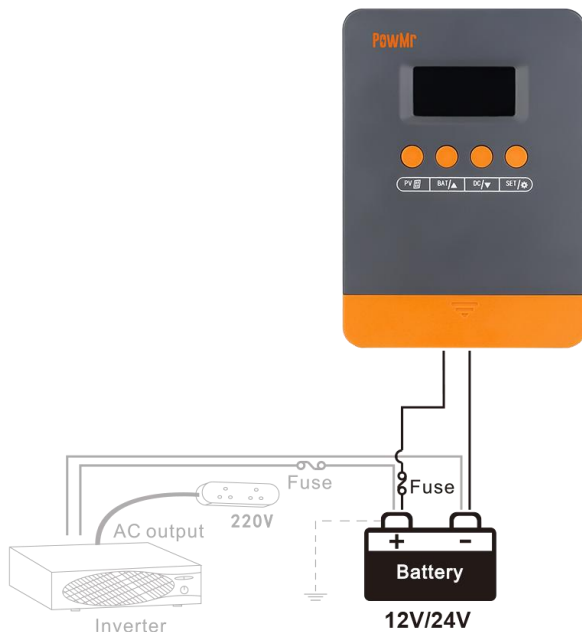

**NOTICE**

- All wiring work must be performed by professionals.
- For safe operation and proper application, corresponding breakers must be installed on the cables connected to the controller, and ensure all connections are tight.
- Ensure all breakers are in the OFF position before completing all wiring.
- Connect the positive cable terminal to the positive port and the negative cable terminal to the negative port.
- The above precautions also apply to PV ports and DC output ports.

**Step 3. PV wiring:** Connect the PV array to the controller using cables.

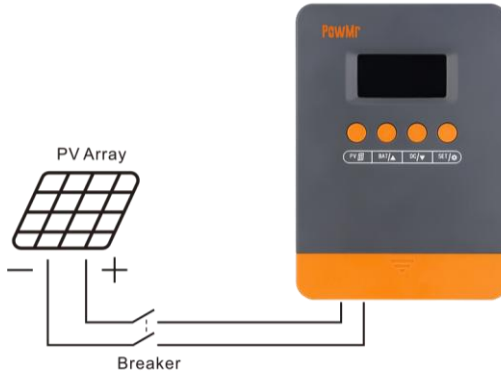

**Step 4. DC output wiring:** Connect the load to the controller using cables.

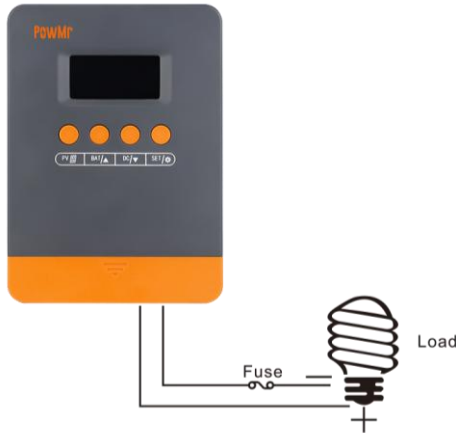

**Step 5. Pre-start check:** Refer to the wiring diagram below. If all connections are accurate and secure, close the battery and PV array breakers in sequence.

**WARNING: Risk of electric shock!**

- Ensure all power sources are off before wiring, and follow appropriate inspection and operation procedures.

### 3 Operation Guide



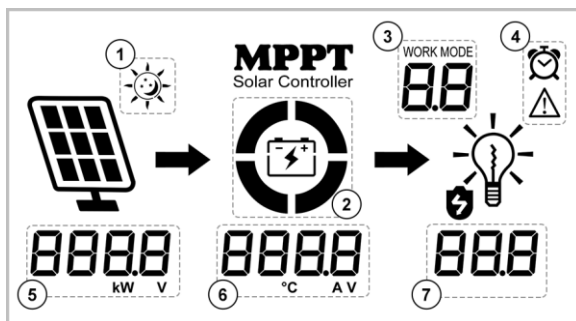

#### 3.1 Button Introduction





No.	Function
①	Day/Night Indicator
②	Indicates remaining battery power.
③	Operation mode (see "3.3 Operation Mode Description").
④	Load periodic operation status and alert status (see "4.2 Troubleshooting").
⑤	Indicates PV input voltage/power.
⑥	Indicates current battery voltage/charging current/device temperature/battery calibration voltage/battery type/boost charging voltage/float charging voltage/DC under-voltage recovery voltage/DC under-voltage cutoff voltage.
⑦	Indicates load operation mode.

## 3.2 Key Introduction



Function key		Description
PV / 	Browsing Mode	Switches PV input parameter information
	BAT / 	Short press: Switches battery information (to the next option) Long press: Enters battery parameter settings
DC / 	Setup Mode	Increases the value
	Browsing Mode	Switches battery information (to the previous option) Long press: Enters load operation mode settings
SET / 	Setup Mode	Decreases the value
	Short Press	Confirms and saves settings
	Long Press	Restores factory settings

**Note:** When long pressing **SET / ** and **BAT / **, please disconnect the PV input to ensure that the settings are made while the battery is not charging.

### 3.3 Operation Mode Description

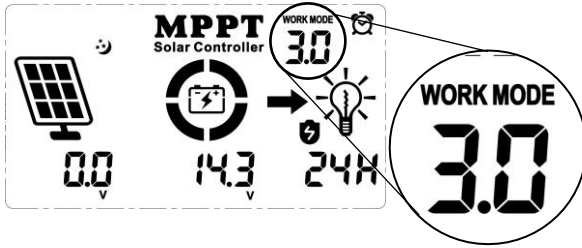

Code	Description
3.0	Night mode, not charging
4.0	Fast charging mode (MPPT mode)
7.0	Boost charging mode
8.0	Float charging mode

**Note:** In case of a fault, the operation mode section will display the fault code. For details, please refer to section 4.2.

### 3.4 Overview of PV Parameters

Short press the **PV /** button, and the data on the left side of the screen will switch as follows.

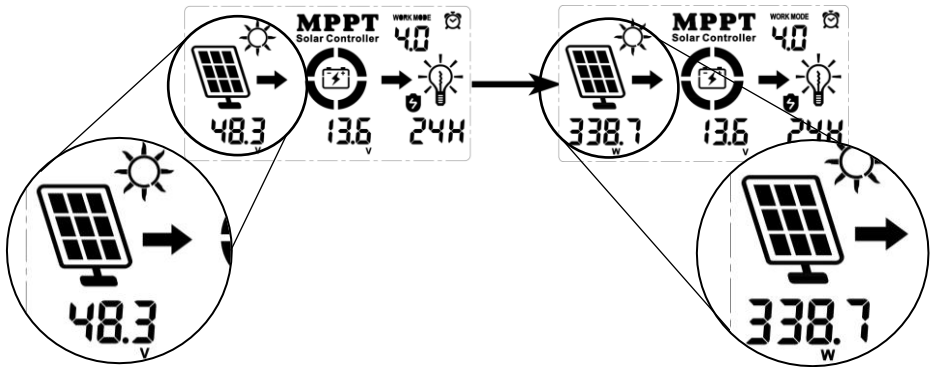

### 3.5 Battery Parameters Overview

In browse mode, use the **BAT/▲** and **DC/▼** keys to scroll through the battery parameters. When you reach the parameter you want to set, long press the **BAT/▲** key to enter parameter setting mode. Once in the specified parameter setting, adjust the value size or toggle options using the **BAT/▲** and **DC/▼** keys, then press the **SET / \*** key to confirm the settings.

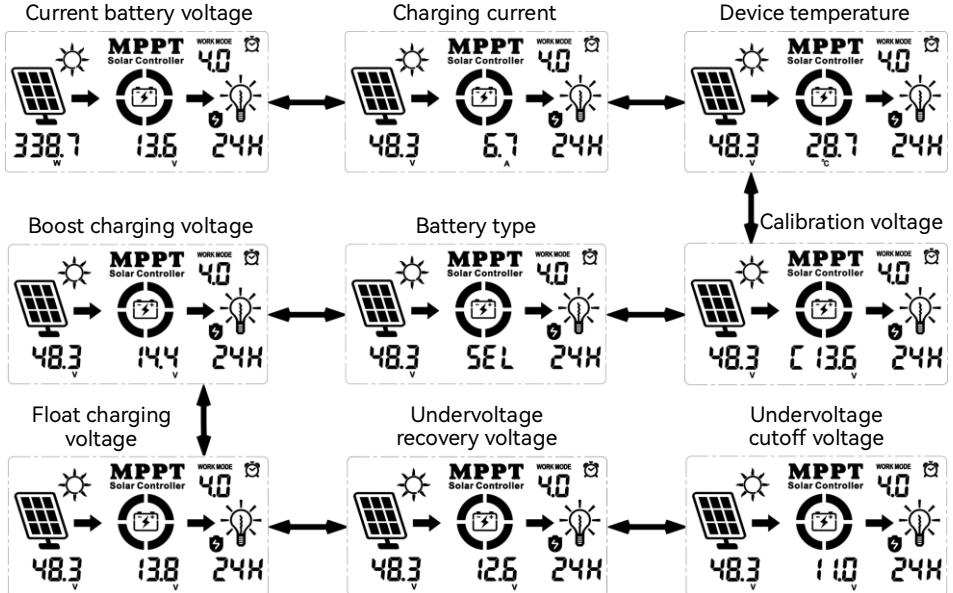

### 3.6 Battery Parameter Settings

**NOTE**

- Before long pressing **BAT/▲** to set the battery parameters, please switch off the PV input to ensure that the battery is not in a charging state.

Below are the configurable settings for battery-related parameters:

#### Battery Calibration Voltage

When there is a discrepancy between the battery voltage monitored by the controller and the value measured by a multimeter, you can calibrate the battery voltage using this setting.

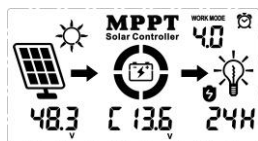

Long press the **BAT/▲** key to enter the setting program. Use the **BAT/▲** and **DC/▼** keys to adjust the value size, then press the **SET / \*** key to save and confirm.

#### Battery Type Selection

Please select the battery type according to the table below based on the connected battery:

Sequence	Display	Battery Type
1	SEL	Sealed lead-acid battery
2	GEL	Gel sealed lead-acid battery
3	FLd	Flooded lead-acid battery
4	L04	4S Lithium iron phosphate battery
5	L07	7 Lithium iron phosphate battery
6	L08	8S Lithium iron phosphate battery
7	N03	3S Lithium-ion battery
8	N06	6S Lithium-ion battery
9	N07	7S Lithium-ion battery
10	USE	User-defined

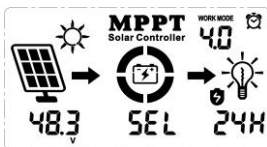

Long press the **BAT/▲** key to enter the setting program. Use the **BAT/▲** and **DC/▼** keys to toggle through the battery type options, then press the **SET / \*** key to save and confirm. If you select User-defined battery type, you can proceed with setting the following battery parameters.

## Custom Configuration of Charging Voltage

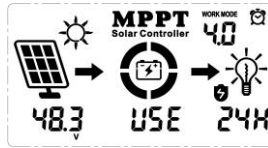

### NOTICE

- If the battery type is set to "USE" (User-defined mode), you can manually adjust the following 5 charging parameters.
- If "USE" is not selected, manual adjustment of charging parameters is not required. The controller will charge based on preset values corresponding to the battery type. Refer to section 3.7 for preset charging values.

## System Voltage Setting Interface

System voltage options: 12V/24V.

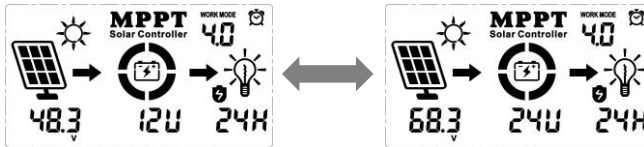

## Boost Charging Voltage Setting Interface

Default: 14.4V, adjustable range: 9.0~17.0V, step size: 0.1V.

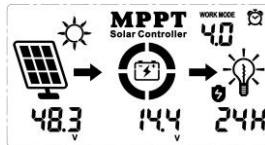

### Float Charging Voltage Setting Interface

Default: 13.8V, adjustable range: 9.0~17.0V, step size: 0.1V.

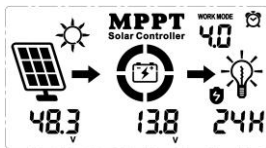

### Under-voltage Recovery Voltage Setting Interface

Default: 12.6V, adjustable range: 9.0~17.0V, step size: 0.1V.

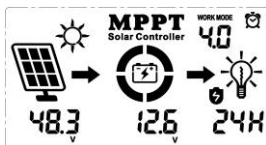

### Under-voltage Cut-off Voltage Setting Interface

Default: 11.0V, adjustable range: 9.0~17.0V, step size: 0.1V.

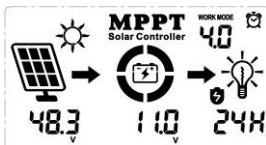

### 3.7 Default Parameters for Different Battery Types

◆ For Lead-acid Batteries and User-defined Batteries:

Battery Type Parameter	FLd	GEL	SEL	USE
Boost Charge Voltage	14.6V	14.2V	14.4V	9.0~17.0V
Float Charge Voltage	13.8V	13.8V	13.8V	9.0~17.0V
Low Voltage Cutoff Voltage	11.0V	11.0V	11.0V	9.0~17.0V
Low Voltage Recovery Voltage	12.6V	12.6V	12.6V	9.0~17.0V

◆ For Lithium-Ion Batterie

Battery Type Parameter	N03	N06	N07
Boost Charge Voltage	12.5V	25.5V	29.2V
Float Charge Voltage	12.2V	24.4	28.5V
Low Voltage Cutoff Voltage	8.4V	16.8V	19.6V
Low Voltage Recovery Voltage	9.0V	18.0V	21.0V

◆ For LiFePO4 Batteries:

Battery Type Parameter	L04	L07	L08
Boost Charge Voltage	14.5V	25.4V	29.0V
Float Charge Voltage	13.8V	24.1V	27.6V
Low Voltage Cutoff Voltage	11.2V	19.6V	22.4V
Low Voltage Recovery Voltage	12.0V	21.0V	24.0V

#### NOTICE

- The charging parameters for lead-acid and user-defined batteries in the above table are based on a 12V system voltage. For 24V system voltage, multiply these values by 2. Similarly, for lead-acid or user-defined battery types with a system voltage of 24V, the actual charging voltage will be twice the displayed voltage on the monitor.

● Three stages of lead-acid battery charging:

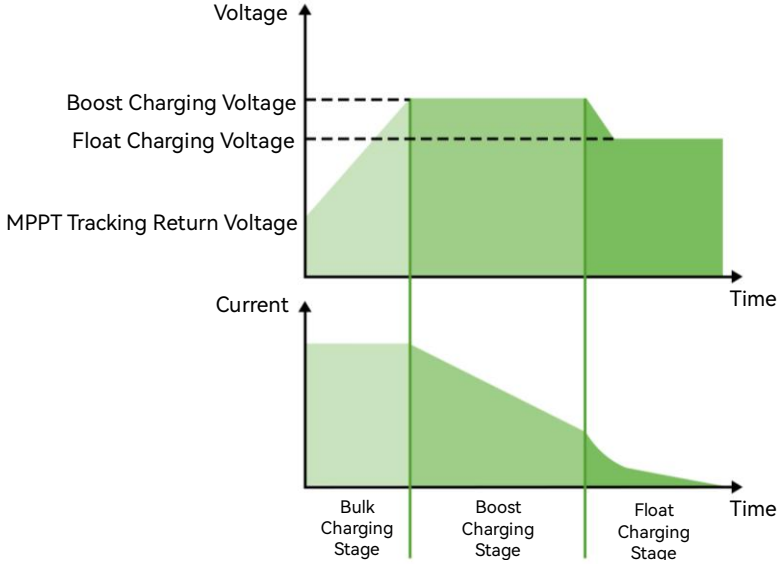

● Two stages of lithium battery charging:

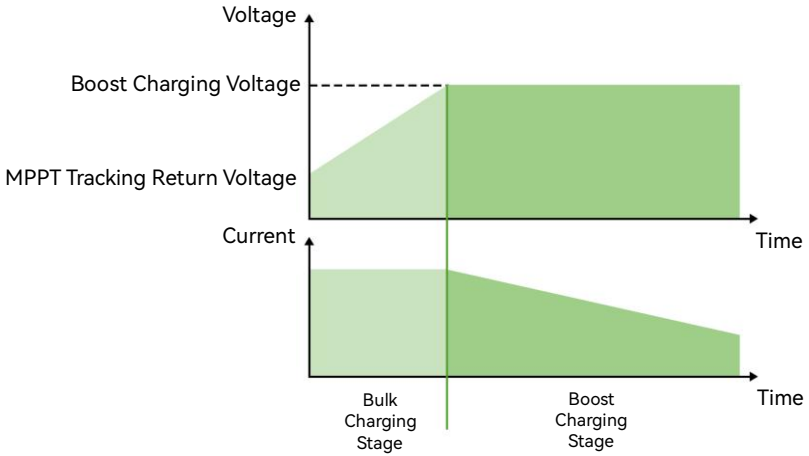

### 3.8 Load Operation Mode Settings

To access the load operation mode settings, press and hold the **DC/▼** button. Then use the **BAT/▲** and **DC/▼** buttons to switch between options, and press the **SET / ✱** button to save and confirm.

Mode Code	Description
00H	Light Control Mode (Load output starts after sunset and stops at sunrise).
24H	Immediate Load On (Press the <b>SET</b> button to immediately turn off the load output).
01H~23H	Adjust the duration of load activation (The value indicates the duration, e.g., 01H for 1 hour, 02H for 2 hours).

## 4 Protection

### 4.1 Protection Functions

Protection	Description
Photovoltaic array short circuit	When a short circuit occurs in the photovoltaic array, the controller will cease charging. Rectifying the short circuit fault will restore operation.
Photovoltaic input overcurrent	The controller limits the battery charging current to the maximum rated value. Therefore, an overcurrent from the photovoltaic array will prevent operation at peak power.
Load overcurrent protection	When the load current reaches its rated value, the controller automatically shuts down the DC output. It will recheck the output after 5 minutes to detect if overcurrent persists.
Photovoltaic polarity reversal	If the photovoltaic wiring polarity is reversed, the controller will not operate. Correct connection is necessary to restore normal operation.
Battery polarity reversal	Similarly, if the battery wiring polarity is reversed, the controller will not function until correct connection is restored.
Overtemperature	When the controller's heatsink temperature exceeds 65°C, it automatically begins reducing the charging current. If it exceeds 80°C, the controller shuts down automatically.

## 4.2 Troubleshooting

When a fault occurs, the controller will display a fault signal (as shown in the diagram below) to assist you in identifying solutions.

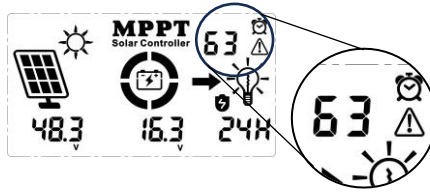

Fault Code	Fault Cause	Solution
18	Input photovoltaic voltage too low	Increase the number of solar panels or connect them in series to raise the photovoltaic input voltage.
60	Overtemperature protection	Allow the equipment to cool to below the recovery temperature to resume normal charging and discharging.
63	Battery voltage too high	Measure to confirm if battery voltage exceeds rated voltage and disconnect photovoltaic array circuit breaker.
65	Battery voltage too low	Charge the battery until voltage exceeds the undervoltage recovery point. Refer to "3.7 Default Parameters for Different Battery Types" for specific details.
71	Input photovoltaic voltage too high	Reduce the number of photovoltaic arrays connected to the controller to lower photovoltaic input; or adjust series and parallel connections to reduce voltage or current values.
73	Overcharging current	
72	Overdischarging current	Reduce output terminal load to ensure total load is within rated limits of the controller and battery.

## 5 Maintenance

We recommend conducting the following checks and maintenance at least twice a year to ensure optimal performance:

1. Ensure the controller is securely mounted in a clean and dry environment.
2. Ensure proper airflow around the controller and clean any dust or debris from the heat sinks.
3. Inspect all exposed wires for insulation damage, such as severe sun exposure, friction wear, dryness, insect or rodent damage. Repair or replace any damaged wires as necessary.
4. Tighten all terminals and check for loose, broken, or burnt cable connections.
5. Confirm that all system components are properly grounded.
6. Ensure all terminals are free from corrosion, insulation damage, high temperatures, or signs of burning/discoloration, and tighten terminal screws.
7. Check for dirt, nesting insects, and corrosion. If present, clean promptly.

**WARNING: Risk of electric shock!**

- Before performing the above operations, ensure that all power sources are turned off and then follow the relevant check and operation guidelines.

## 6 Specification Parameters

Models	25A	35A	45A
<b>Solar Input Parameters</b>			
<b>Max. Input Power:</b>			
For 12V System	300W	420W	540W
For 24V System	600W	840W	1080W
<b>Input Voltage Range:</b>			
For 12V System	<60V	<80V	<100V
For 24V System	<60V	<80V	<100V
<b>Battery Charging Parameters</b>			
Charging Technology	MPPT		
Charging Algorithm	3 Stages		
Nominal System Voltage	12V/24V		
Battery Voltage Range	9~30V		
Rated Charging Current	25A	35A	45A
Conversion Efficiency	≤98%		
Max. Power Point Tracking Efficiency	>99%		
Temperature Compensation	-3mV/°C/2V (default)		
Self-Consumption	44mA/12V; 26mA/24V		
<b>DC Output Parameters</b>			
Rated DC Output Current	15A	20A	25A
<b>General Parameters</b>			
IP Class	IP32		
Operating Temperature Range	-35°C~+45°C		
Humidity Range	≤95% Non-condensing		
Altitude	<3000m		
Dimensions	160x115x51mm	195x135x65mm	195x135x65mm
Net Weight	500g	900g	1035g



# POWMr

SHENZHEN HEHEJIN INDUSTRIAL CO.,LTD

Tel/Fax: +86 755-28219903

Email: [support@powmr.com](mailto:support@powmr.com)

Web: [www.powmr.com](http://www.powmr.com)

Add: Henggang Street, Longgang District, Shenzhen, Guangdong, China