

Contents

1. Safety Precautions	1
1.1. Safety Definition	1
1.2. Warning Symbols	1
1.3. Safety Guidelines	2
2. Product Overview	4
2.1. Nameplate	4
2.2. Type Designation Key	4
2.3. Product Specifications	5
2.4. Rated Specifications	5
2.5. Products Dimensions	9
3. Installation Guidelines	10
3.1. Mechanical Installation	10
3.1.1. Installation Environment	10
3.1.2. Installation Direction	11
3.1.3. Installation Manner	11
3.2. Standard Wiring	12
3.2.1. Electrical Power Connections	12
3.2.2. Terminals of Main Circuit	12
3.2.3. Terminals of Control Circuit	13
4. Keypad Operation	14
4.1. Operation Panel	14
4.2. Description of Keys on the Operation Panel	14
4.3. Example of Key Operation	14
4.3.1. Run and Stop	14
4.3.2. Operating Displays	14
4.3.3. Changing Parameters	15
4.3.4. Selecting Parameters	15
4.3.5. Parameter Factory Reset	15
4.3.6. Commissioning	15
4.3.7. Inspection Before Operation	15
4.3.8. Trial Run	16
4.3.9. Parameter Setting	16
5. Function Parameters	17
5.1. Description of Parameter	17
5.2. Common Function Parameters	24
6. Fault Diagnosis and Solution	27
6.1. Error and Solutions of Solar Pump Inverter	27
6.2. Common Faults and Solutions	31
6.3. Maintenance Bond	32
Warranty Card	33

1. Safety Precautions

Please read this manual carefully and follow all safety precautions before moving, installing, operating and servicing the inverter. If ignored, physical injury or death may occur, or damage may occur to the devices. If any physical injury or death or damage to the devices occurs for ignoring to the safety precautions in the manual, our company will not be responsible for any damages and we are not legally bound in any manner.

1.1. Safety Definition

Danger: Serious physical injury or even death may occur if not follow relevant requirements









Warning: Physical injury or damage to the devices may occur if not follow relevant requirements

Note: Physical hurt may occur if not follow relevant requirements





Qualified electricians: People working on the device should take part in professional electrical and safety training, receive the certification and be familiar with all steps and requirements of installing, commissioning, operating and maintaining the device to avoid any emergency.

1.2. Warning Symbols

Warnings caution you about conditions which can result in serious injury or death and/or damage to the equipment, and advice on how to avoid the danger. Following warning symbols are used in this manual:

Symbols	Name	Instruction	Abbreviation
 Danger	Danger	Serious physical injury or even death may occur if not follow the relative requirements.	
 Warning	Warning	Physical injury or damage to the devices may occur if not follow the relative requirements.	
 Do not	Electrostatic discharge	Damage to the PCBA board may occur if not follow the relative requirements.	
 Hot sides	Hot sides	Base of the device may become hot. Do not touch.	
Note	Note	Physical hurt may occur if not follow the relative requirements	Note

1.3. Safety Guidelines

	<ul style="list-style-type: none"> ● Only qualified electricians are allowed to operate on the inverter. ● Do not carry out any wiring and inspection or changing components when the power supply is applied. Ensure all input power supply is disconnected before wiring and checking and always wait for at least the time designated on the inverter or until the DC bus voltage is less than 36V. Below is the table of the waiting time: 		
	Inverter model		Minimum waiting time
	1PH 220V	0.4KW-2.2KW	5 minutes
	3PH 220V	4KW-7.5KW	5 minutes
	3PH 380V	0.75KW-37KW	5 minutes
	<ul style="list-style-type: none"> ● Do not refit the inverter unauthorized; otherwise fire, electric shock or other injury may occur. 		
	<ul style="list-style-type: none"> ● The base of the radiator may become hot during running. Do not touch to avoid hurt. 		
	<ul style="list-style-type: none"> ● The electrical parts and components inside the inverter are electrostatic. Take measurements to avoid electrostatic discharge during relevant operation. 		

Delivery and Installation

	<ul style="list-style-type: none"> ● Please install the inverter on fire-retardant material and keep the inverter away from combustible materials. ● Do not operate on the inverter if there is any damage or components loss to the inverter. ● Do not touch the inverter with wet items or body, otherwise electric shock may occur.
---	---

Note:

- Select appropriate moving and installing tools to ensure a safe and normal running of the inverter and avoid physical injury or death. For physical safety, the erector should take some mechanical protective measurements, such as wearing safety shoes and working uniforms.
- Do not carry the inverter by its cover. The cover may fall off.
- Non-professionals are forbidden to open the inverter cover.
- Install away from children and other public places.
- The inverter cannot meet the requirements of low voltage protection in IEC61800-5-1 if the altitude of installation site is above 2000m.
- The leakage current of the inverter may be above 3.5mA during operation. Ground with proper techniques and ensure the grounding resistor is less than 10Ω. The conductivity of PE grounding conductor is the same as that of the phase conductor (with the same cross-sectional area).

Commissioning and Running

	<ul style="list-style-type: none"> ● Disconnect all power supplies applied to the inverter before the terminal wiring and wait for at least the designated time after disconnecting the power supply. ● High voltage is present inside the inverter during running. Do not carry out any operation except for the keypad setting. ● The inverter cannot be used as “Emergency-stop device”. ● If the inverter is used to break the motor suddenly, a mechanical braking device should be provided.
---	--

Note:

- Do not switch on or off the input power supply of the inverter frequently.
- For inverters that have been stored for a long time, check and fix the capacitance and try to run it again before utilization.
- Cover the front board before running, otherwise electric shock may occur.



Maintenance and Replacement of Components

	<ul style="list-style-type: none"> ● Only qualified electricians are allowed to perform the maintenance, inspection, and components replacement of the inverter. ● Disconnect all power supplies to the inverter before the terminal wiring. ● Wait for at least the time designated on the inverter after disconnection. ● Take measures to avoid screws, cables and other conductive materials to fall into the inverter during maintenance and component replacement and anti-static measures should be taken for the inverter and internal devices.
---	---

Note:

- Please select proper torque to tighten screws.
- Keep the inverter, parts and components away from combustible materials during maintenance and component replacement.
- Do not carry out any isolation voltage-endurance test on the inverter and do not measure the control circuit of the inverter by megohmmeter.

Scrap Treatment

	<ul style="list-style-type: none"> ● There are heavy metals in the inverter. Deal with it as industrial effluent.
	<ul style="list-style-type: none"> ● When the life cycle ends, the product should enter the recycling system. Dispose of it separately at an appropriate collection point instead of placing it in the normal waste stream.

2. Product Overview

We Solar Pump Inverter have been tested and inspected before leaving the manufacturer. Before unpacking the product, please check product packaging for shipping damage caused by careless transportation and whether the specifications and type of the product complies with the order. If any questions, please contact the supplier of we products, or directly contact the company.

※ Inspect that the contents are complete (PV500 series Solar Pump Inverter, operation manual, keyboard extension line each unit.)

※ Check the nameplate on the side of the Solar Pump Inverter to ensure that the product you have received is the right one you ordered.

2.1. Nameplate

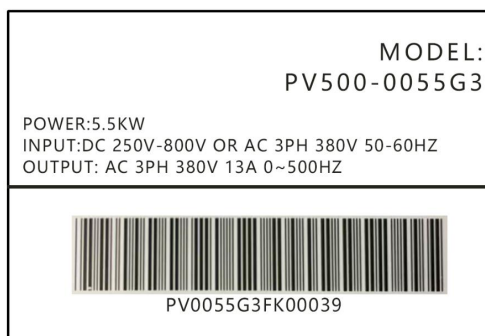

Figure 2-1 Name plate

Note: This is the example of PV500 standard products and the CE\TUV\IP20 certifications are marked according to the reality.

2.2. Type Designation Key

The type designation contains information on the inverter. The user can find the type designation on the type designation label attached to the inverter or the simple name plate.

PV500	0055	G1
①	②	③

Key	Sign	Description	Remarks
Product abbreviation	①	Product abbreviation	PV500 Series
Rated power	②	Power range	0.75-500KW
Voltage degree	③	Voltage degree	G1: AC 1PH 220V (-15%) ~240(+10%) G2: AC 3PH 220V (-15%) ~240(+10%) G3: AC 3PH 380V (-15%) ~440(+10%)

2.3. Product Specifications

Model	G1	G2	G3
AC Input Voltage (V)	220(-15%) ~240 (+10%) (1PH)	220(-15%) ~240 (+10%) (3PH)	380(-15%) ~440 (+10%) (3PH)
Max. DC Voltage (V)	400	400	800
Start-up Voltage (V)	215	180	370
Lowest Working Voltage (V)	200	150	350
Recommended DC Input Voltage Range (V)	200~400	200~400	360~750
Recommended MPPT Voltage (V)	330	330	550

2.4. Rated Specifications

Single-phase power supply: 220V, 50/60Hz					
Type	Drive Motor	Power Capacity	Input Current	Output Current	Shape Case
	KW	KVA	A	A	
PV500-0007G1	0.75	1	4.2	4	000
PV500-0015G1	1.5	2	14	7	000
PV500-0022G1	2.2	3	23	10	001
Three -phase power supply: 220V, 50/60Hz					
Type	Drive Motor	Power Capacity	Input Current	Output Current	Shape Case
	KW	KVA	A	A	
PV500-0040G2	4	5	18.1	16	002
PV500-0055G2	5.5	7.5	28	25	003
PV500-0075G2	7.5	10	37.1	32	003
PV500-0110G2	11	15	49.8	45	004
PV500-0150G2	15	20	65.4	60	005
PV500-0185G2	18.5	25	81.6	75	005
PV500-0220G2	22	30	97.7	90	006
PV500-0300G2	30	40	122.1	110	007
PV500-0370G2	37	50	157	150	007

PV500-0450G2	45	60	185	170	007
PV500-0550G2	55	70	215	210	008
PV500-0750G2	75	100	320	300	009
Input Specification					
PV Input					
Maximum Input DC Voltage	400VDC				
Recommended MPPT Voltage Range	250~350VDC				
Recommended Input Operation Voltage	320VDC				
Grid or Backup Generator Input					
Input Voltage	Single phase 220V (-15%~30%)				
Output Specification					
Rated Output Voltage	3PH 220V				
Output Frequency	0~500.00Hz (default: 0~50.00Hz)				
Protection					
Built-in Protection	Lighting Protection, over-current, over voltage, output phase-lose, under-load, under-voltage, short circuit, overheating, water pump idling etc.				

Three-phase power supply: 380V, 50/60Hz					
Type	Drive Motor	Power Capacity	Input Current	Output Current	Shape Case
	KW	KVA	A	A	
PV500-0007G3	0.75	1	3.4	2.1	A00
PV500-0015G3	1.5	2	5	3.8	A00
PV500-0022G3	2.2	3	5.8	5	A00
PV500-0030G3	3.0	4	8.4	7	A00
PV500-0040G3	4	5	10.5	9	A01
PV500-0055G3	5.5	7.5	14.6	13	A01
PV500-0075G3	7.5	10	20.5	17	A02
PV500-0110G3	11	15	26	25	A02
PV500-0150G3	15	20	35	32	A03
PV500-0185G3	18.5	25	38.5	38	A03
PV500-0220G3	22	30	46.5	45	A04

PV500-0300G3	30	40	62	60	A04
PV500-0370G3	37	50	76	75	A05
PV500-0450G3	45	60	92	90	A05
PV500-0550G3	55	70	113	110	A06
PV500-0750G3	75	100	157	150	A07
PV500-0930G3	93	125	180	170	A07
PV500-1100G3	110	150	214	210	A08
PV500-1320G3	132	175	256	250	A08
PV500-1600G3	160	210	307	300	A09
PV500-2000G3	200	260	385	380	A10
PV500-2200G3	220	300	430	415	A10
PV500-2500G3	250	350	468	470	A11
PV500-2800G3	280	370	525	520	A11
PV500-3150G3	315	400	590	585	A11
PV500-3550G3	355	470	650	650	A12
PV500-4000G3	400	530	725	725	A12
PV500-4500G3	450	595	820	820	A12
PV500-5000G3	500	595	980	980	A12
PV500-5600G3	560	740	1080	1080	A13
PV500-6300G3	630	830	1200	1200	A13

Input Specification

PV Input

Maximum Input DC Voltage	800VDC
Recommended MPPT Voltage Range	450~650VDC
Recommended Input Operation Voltage	540VDC

Grid or Backup Generator Input

Input Voltage	Three phase 380V (-15%~30%)
---------------	-----------------------------

Output Specification

Rated Output Voltage	3PH 380V
Output Frequency	0~500.00Hz (Default 0~50.00Hz)

Protection

Built-in Protection	Lighting Protection, over-current, over voltage, output phase-lose, under-load, under-voltage, short circuit, overheating, water pump idling etc.
General Parameters	
Application Site	No direct sunshine, no dust, corrosive gas, combustible gas, oil mist, steam, dripping or salinity etc.
Altitude and Derating Use	0~2000 m
	Derated use above 1000m, per 100m, the rated output current decrease 1%.
Environment Temperature and Derating Use	-10℃~40℃ (Environment Temperature be 40℃~50℃, please keep derated use.)
Humidity	≤ 95%, non-condensation
Vibration	less than 5.9 m/s ² (0.6g)
Storage Temperature	-40℃~+70℃
Efficiency	Rated Power Run ≥ 93%
Installation	Wall or rail mounting
Protection Grade	IP20
Cooling	Forced Air Cooling

2.5. Products Dimensions

No.	Power	Dimension(mm)			Installation Size(mm)		Hole ϕ
		W	D	H	W1	H1	
A00	0.75~2.2KW/220V 0.75~2.2KW/380V	170	86	141	157	75	5mm
A01	4.0~5.5KW/380V 4.0/220V	188	96	171	176	83.6	5mm
A02	7.5~11KW	228	114	192	214.5	98.7	5mm
A03	15~18.5KW	290	160	182	269	143	6.5mm
A04	22~30KW	328	193	217	305	172	8.5mm
A05	37~45KW	344	228	223	324	206	8.5mm
A06	55KW	490	327.5	238	459	202.5	10mm
A07	75~93KW	528	300	279	504	200	9mm
A08	110~132KW	690	370	360	636.5	232	10mm
A09	160KW	724	428	358.5	693	330	10mm
A10	200~220KW	794	453	358.5	763	330	10mm
A11	250~315KW	1060	650	392.5	1030	420	12mm
A12	355~500KW	1361.5	818	404.5	1280	520	16mm
A13	560~630KW	1330	786	410	1295	500	16mm

*Due to Product upgrade, size update without prior notice, Consult staff for details

3. Installation Guidelines

The chapter describes the mechanical installation and electric installation.

	<ul style="list-style-type: none"> ● Only qualified electricians are allowed to carry out what described in this chapter. Please operate as the instructions in Safety precautions. Ignoring these may cause physical injury or death or damage to the devices. ● Ensure the power supply of the inverter is disconnected during the operation. Wait for at least the time designated after the disconnection if the power supply is applied. ● The installation and design of the inverter should be complied with the requirement of the local laws and regulations in the installation site. If the installation infringes the requirement, our company will exempt from any responsibility. Additionally, if users do not comply with the suggestion, some damage beyond the assured maintenance range may occur.
---	--

3.1. Mechanical Installation

3.1.1. Installation Environment

The installation environment is the safeguard for a full performance and long-term stable functions of the inverter. Check the installation environment as follows:

Environment	Conditions
Installation site	Indoor
Environment temperature	<p>The ambient temperature of inverter is $-10^{\circ}\text{C}\sim 50^{\circ}\text{C}$ while air temperature change should be less than 0.5°C per minute.</p> <p>The inverter will be derated once ambient temperature exceeds 40°C. It is not recommended to use the inverter if ambient temperature is above 50°C.</p> <p>To ensure reliability, do not use the inverter if the ambient temperature changes frequently.</p> <p>Provide cooling fan or air conditioner to control the internal ambient temperature below the required one if the inverter is used in a close space such as in the control cabinet.</p> <p>When the temperature is too low, if the inverter needs to restart to run after a long stop, it is necessary to provide an external heating device to increase the internal temperature, otherwise damage to the devices may occur.</p>
Humidity	$\text{RH}\leq 95\%$. No condensation is allowed.
Storage temperature	$-40^{\circ}\text{C}\sim +70^{\circ}\text{C}$. The temperature change rate is less than $1^{\circ}\text{C}/\text{minute}$.
Running environment condition	<p>The installation site of the inverter should:</p> <ul style="list-style-type: none"> Keep away from the electromagnetic radiation source; Keep away from contaminative air, such as corrosive gas, oil mist and flammable gas; Ensure foreign objects, such as metal power, dust, oil, water cannot enter into the inverter (do not install the inverter on the flammable materials such as wood); Keep away from direct sunlight, oil mist, steam and vibration environment.
Pollution	Pollution degree 2

Altitude	Below 1000m If the altitude is above 1000m, please derate 1% for every additional 100m.
Vibration	$\leq 5.8\text{m/s}^2(0.6\text{g})$
Installation direction	The inverter should be installed on an upright position to ensure sufficient cooling effect.

Note:

- PV500 series inverters should be installed in a clean and ventilated environment according to enclosure classification.
- Cooling air must be clean, free from corrosive materials and electrically conductive dust.

3.1.2. Installation Direction

The inverter may be installed on the wall or in a cabinet.

The inverter needs be installed in the vertical position. Check the installation site according to the requirements below.

3.1.3. Installation Manner

The clearance that needs to be reserved varies with the power class of the PV500 Series, as shown in the following figure.

Figure 3.1.2 Clearance around the PV500 Series for installation

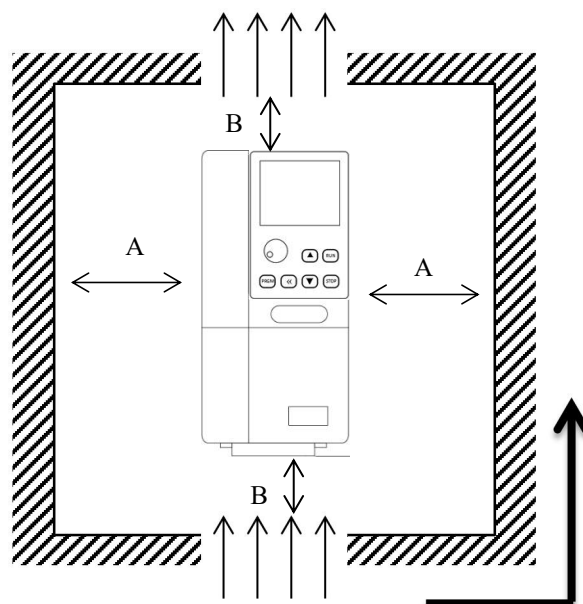

Figure 3.1.2

Installation clearance requirements on the M550 series Solar Pump Inverter of different power classes.

Power Class	Clearance Requirements	
0.75kW~22kW	$A \geq 10$	$B \geq 200$
30kW~37kW	$A \geq 50$	$B \geq 200$
45kW~110kW	$A \geq 50$	$B \geq 300$

- When transporting Solar Pump Inverter, right lifting tools are required to prevent Solar Pump Inverter.
- Please don't run the Solar Pump Inverter if there is damage or lacking of components.
- Do not place heavy objects on the Solar Pump Inverter.
- Please prevent screw, cable pieces or other conductive objects or oil inflammable objects invading the Solar Pump Inverter.
- Do not make it fall or have a strong impact.
- Confirm if the installation location and object could withstand the weight of the Solar Pump Inverter.

3.2. Standard Wiring

3.2.1. Electrical Power Connections

The figure below shows the standard wiring of inverter.

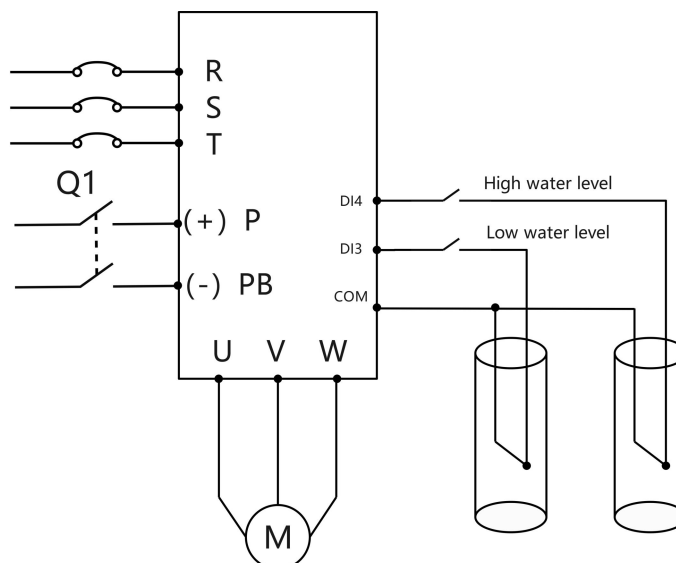

Figure 3-3 Standard wiring diagram

	<ul style="list-style-type: none"> ● The DC breaker Q1 must be installed as the protection switch for PV input. ● In parallel connection, the combination box special for PV must be used. ● When the distance between the PV input component and inverter exceeds 10 meters, type-II surge protection devices must be configured at the DC side. ● When the distance between the pump and inverter exceeds 50 meters, it is recommended to configure output reactors. ● The inverter automatically runs after being powered on. If parameters need to be set, follow the parameter setting instructions in chapter 6. ● Before connecting the braking resistor cable, remove the yellow labels of PB, (+), and (-) from the terminal blocks. Otherwise, poor connection may occur.
--	---

3.2.2. Terminals of Main Circuit

Terminal	Name	Function
R, S, T (L, N)	AC input	3PH (1PH) AC input terminals, connected to the grid Note: Use the screws equipped with the inverter for wiring.
(+), (-) PB, P	PV input	Solar cell panel input terminals
U, V, W	Inverter output	3PH/1PH AC output terminals, connected to the pump motor Note: 1PH motors must connect to terminals U and W.
⊕	Safety grounding	Safety protection grounding terminal. Each inverter must be grounded

3.2.3. Terminals of Control Circuit

Type	Terminal	Terminal Name	Function Description
Power Output	+10V-GND	Terminal of 10V power output	Provide +10V power supply for external units, with maximum output current of 10mA. It is generally used as the operating power supply for the external potentiometer. The potentiometer resistance range is 1-5kΩ.
Analog Input	AI1-GND	Analog input terminal 1	F-049 set voltage and current mode.
	AI2-GND	Analog input terminal 2	F-049 set voltage and current mode.
Digital Input	DI1-COM	Digital Input 1	Optical coupling isolation, bipolar input.
	DI2-COM	Digital Input 2	
	DI3-COM	Digital Input 3	
	DI4-COM	Digital Input 4	
	DI5-COM	Digital Input 5	
Analog Output	AO1-GND	Analog output	F-049 set voltage and current mode.
	AO2-GND	Analog output	F-049 set voltage and current mode.
Digital Output	DO1-COM	Digital output	Optical coupling isolation, dual polarity open collector output. Output voltage range: 0-24V.
	DO2-COM	Digital output	Optical coupling isolation, dual polarity open collector output. Output voltage range: 0-24V.
Relay Output	T/B-T/C	Normally closed	Contact driving capacity: 250Vac, 3A; 30Vdc, 1A
	T/A-T/B	Normally open	
485 Communication Interface	S+/S-	485 communication interface	Respectively are the positive end of 485 differential signal and the negative end of 485 differential signal (reference ground: GND). Standard 485 communication interface, please use twisted pair or shielded cable.

4. Keypad Operation

4.1. Operation Panel

You can modify the parameters, monitor the working status and start or stop the Solar Pump Inverter by operating the operation panel, as shown in the following figure.

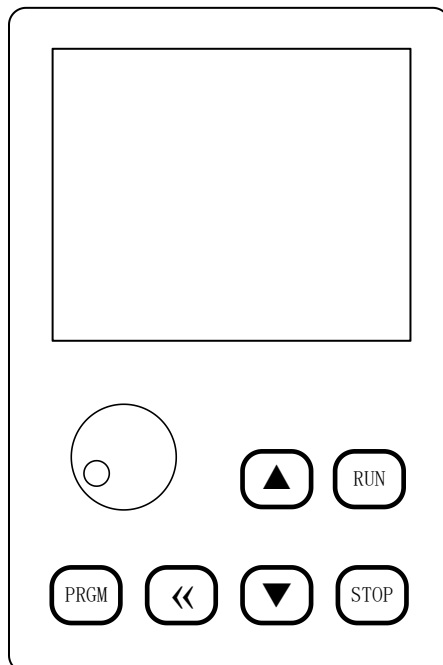

Operation panel figure

Function indicator lamp instructions

FWD: Solar pump inverter forward indicator lighting

REV: Solar pump inverter reset indicator lighting

STOP: Solar pump inverter pause indicator lighting

ALM: Solar pump inverter fault indicator lighting

4.2. Description of Keys on the Operation Panel

Key sign	Name	Function description
PRGM	Program/Enter	Press and hold for 3 seconds to enter or exit menu. Press shortly to read or write parameters.
▲	Increase	Increase the data or the function code.
▼	Decrease	Decrease the data or the function code.
<<	Shift	Select the parameter modification and display content.
RUN	Run Forward/ Reverse	Panel start.
STOP	Stop/Reset	Stop/reset operation.

4.3. Example of Key Operation

4.3.1. Run and Stop

After power on, press the start key to run the inverter, and the stop key to stop the inverter. The operation indicator is always on when the inverter is running; when the inverter is stopped, the stop indicator is always on.

4.3.2. Operating Displays

When the inverter is running, the lower display screen displays the output frequency by default. Press the "<<" , and the display screen will switch between various operation interfaces, starting from the output

frequency, and then display the motor speed, DC bus voltage, output current, output power in turn. Examples are shown in the figure below.



4.3.3. Changing Parameters

When the inverter displays the main interface, long press “PRGM” for 3 seconds to enter the first-level menu interface, and then select the parameters to access at the primary menu interface through “▼/▲”, short press “PRGM” to enter the secondary menu interface, where the value can be inquired or modified.

When the inverter displays the secondary menu interface, long press “PRGM” for 3 seconds or short press “PRGM” can be sent back to the primary menu interface, but long press “PRGM” for 3 seconds will not save the modified parameters. When the inverter displays the primary menu interface, press “PRGM” to return to the main interface. Figure below shows an example of changing F-005 from 5.0 to 10.0.

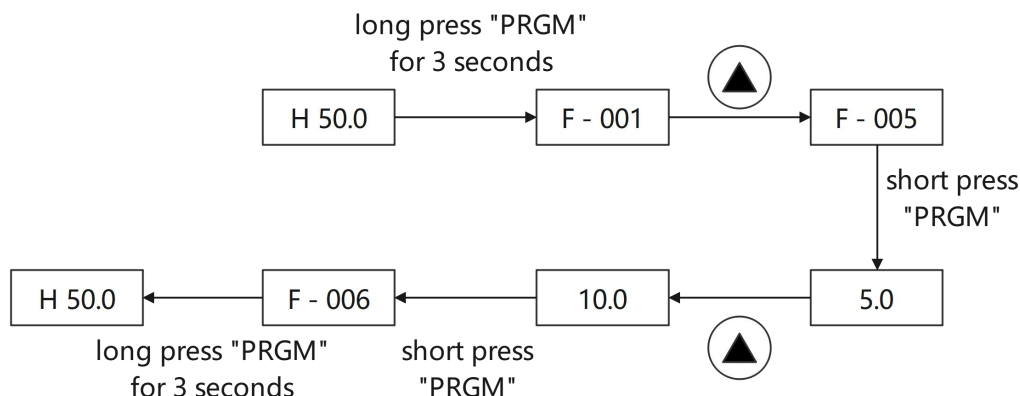

4.3.4. Selecting Parameters

When the inverter displays the primary menu interface, press "Up" or "Down" to switch the parameters you want to access.

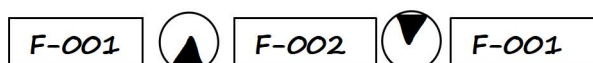

The inverter also has the monitoring parameters. The method to view them is to first select the parameters as F-001 at the first-level parameter interface, and then short press "PRGM" to enter the access interface of the monitoring parameters.



4.3.5. Parameter Factory Reset

The parameter F-064 can be used to default the inverter. F-064 default value is 0, when setting to 1 and short press "PRGM" to reset the parameters to the factory default value.

4.3.6. Commissioning

	<ul style="list-style-type: none"> ● Disconnect all power supplies applied to the inverter before the terminal wiring and wait for at least the designated time after disconnecting the power supply. ● High voltage is present inside the inverter during running. Do not carry out any operation except for the keypad setting. ● The inverter automatically runs once power on. If parameters need to be set, follow the guidelines in this chapter.
--	--

4.3.7. Inspection Before Operation

Before powering on the inverter, ensure that:

- a. The inverter is grounded reliably.

- b. The wiring is correct and reliable.
- c. The AC/DC breaker is selected correctly.
- d. The PV input voltage is in the allowed range of the inverter.
- e. The type, voltage, and power of the motor match those of the inverter.

4.3.8. Trial Run

Close the DC breaker. The inverter automatically runs with a delay of 10 seconds. Check the water yield of the pump. If the water yield is normal, the trial run is successful. If the water yield is under the normal value, exchange any two motor cables, connect the cables, and perform trial run again.

4.3.9. Parameter Setting

After the inverter is powered on, if you need to set parameters, long press the PRGM key for 3 seconds, enter the parameter modification interface to set parameters, short press PRGM to save, disconnect the power switch and close it, and then put it into operation again.

5. Function Parameters

“○”: means the set value of the parameter can be modified on stop and running state;

“⊙”: means the set value of the parameter cannot be modified on the running state;

“●”: means the value of the parameter is the real detection value which cannot be modified;

Note: The inverter implements auto checking and restriction on the parameter modification property. This prevents users from modifying parameters by incorrect operation.

5.1. Description of Parameter

Parameter	Description	Minimum Value	Default Value	Maximum Value	Unit	Change Permission
F-001	Maximum frequency	F-002	50	500	Hz	○
	Maximum output frequency of the inverter.					
F-002	Minimum frequency	0	20	F-001	Hz	○
	Minimum output frequency of the inverter.					
F-003	Preset frequency	F-002	50	F-001	Hz	○
	When the target frequency is selected as “Digital Settings”, parameter sets the initial value of the target frequency of the inverter. This parameter temporarily gets invalid after modifying the target frequency with the “Up / Down” key, unless it is modified again.					
F-004	Output phase sequence	0	0	1	-	○
	0: U V W 1: U W V This parameter changes the motor direction without changing the motor wiring. Note: This parameter initializes to 0 after the parameter default, so be cautious when using in some cases when motor running direction is prohibited to change.					
F-005	Acceleration time	0.1	Type Dependent	500	s	○
	Acceleration time required for the inverter to accelerate from 0 Hz to the maximum frequency (F-001).					
F-006	Deceleration time	0.1	Type Dependent	500	s	○
	The deceleration time required for the inverter to decelerate from the maximum frequency (F-001) to 0 Hz.					
F-007	Stop mode	0	1	1	-	○
	0: Ramp to stop. After the stop command is valid, the inverter reduces the output frequency according to the deceleration time, and stops after the output frequency is reduced to 0.					
F-008	Start command source	0	0	2	-	○
	0: Panel control (LED off) . Press the RUN key to run, and press the STOP key to stop. 1: Terminal control (LED on) . The inverter is directly controlled by the control terminal. By default, DI1 controls forward run and DI2 controls reverse run. 2: Communication control (LED flash) . Controlled via Modbus RTU (RS485).					
F-009	Auto-start enable	0	1	1	-	○
	0: disable 1: enable					
F-010	Auto-start enable delay	0	60	3600	s	○
F-011	Target frequency setting source	0	7	9	-	⊙
	0: Digital setting. The initial frequency is set by F-003, and then modified by UP / DOWN. 1: Keyboard potentiometer settings. When the potentiometer rotates clockwise, the target frequency increases linearly. 2: AI1 set. When the signal of the analog input 1 increases, the target frequency increases					

Parameter	Description	Minimum Value	Default Value	Maximum Value	Unit	Change Permission
	linearly. 3: AI2 set. When the signal of the analog input 2 increases, the target frequency increases linearly. 4: Reserved 5: Reserved 6: Reserved 7: MPPT 8: Communication Settings. Controlled via Modbus RTU (RS485). 9: Reserved					
F-012	Rated power This parameter is set to the rated power of the motor (nameplate).	Type Dependent			KW	⊙
F-013	Rated voltage This parameter is set to the rated voltage of the motor (nameplate).	1	380	500	V	⊙
F-014	Rated current This parameter is set to the rated current of the motor (nameplate).	Type Dependent			A	⊙
F-015	Rated frequency This parameter is set to the rated frequency of the motor (nameplate).	0	50	500	Hz	⊙
F-016	Rated speed This parameter is set to the rated speed of the motor (nameplate).	1	1460	65535	Rpm	⊙
F-017	V/F curve setting 0: Linear V/F. Suitable for the normal constant torque load. 2: Square V/F. Suitable for centrifugal load such as fan and pumps.	0	0	2	-	⊙
F-018	V/F torque boost To compensate torque characteristics at the low frequency, increasing the output voltage at the low frequency. However, if the torque boost is too large, the motor is easy to get hot, the inverter is easy to be over current. It is recommended to increase this parameter when the load is heavy and the motor starting torque is insufficient. Torque boost can be reduced when the load is light.	0.00%	Type Dependent	30.00%	-	○
F-019	V/F Torque boost cutoff frequency Below this frequency, the output torque increase in V / F mode, torque boost is invalid when the output frequency is over this parameter.	0	50	F-015	Hz	⊙
F-020	Carrier frequency This parameter changes the carrier frequency of the inverter. When the carrier frequency is low, the high-order harmonics of output current increases, this leads to the increasing motor loss, and the high motor. When the carrier frequency is high, the motor loss is reduced, the motor temperature rise decreases, but the inverter loss increases, the inverter temperature rise increases, and the interference get worse.	1.0	Type Dependent	16	kHz	○
F-021	VMPP voltage setting source 0: Keyboard reference 1: MPPT track	0	1	1	-	○
F-022	VMPP voltage keypad setting If F-021 is 0, the voltage reference is decided by the function code. (During testing, the voltage reference should be lower than the PV input voltage, otherwise the system will operate at the minimum frequency)	250	Type Dependent	800	V	○

Parameter	Description	Minimum Value	Default Value	Maximum Value	Unit	Change Permission
F-023	Acceleration PID proportional gain Kp	0.0	20.0	100.0	-	○
	The proportional gain of the PID controller determines the regulatory strength of the whole PID regulator, and the larger the Kp value, the greater the regulatory strength. If this value is large, the inverter can respond quickly and the output frequency is changed greatly, even the difference between the reference and the feedback is very small. But the large value can lead to instability.					
F-024	Acceleration PID integration time Ki	0.01	0.5	10.00	s	○
	The PID controller integration time, which determines the intensity of the PID regulator integration adjustment, and the shorter the integration time, the greater the adjustment intensity. The system is easy to oscillate if this parameter value is too small.					
F-025	Deceleration PID proportional gain Kp	0.0	20.0	100.0	-	○
	Same as F-023					
F-026	Deceleration PID integration time Ki	0.01	0.05	10.00	s	○
	Same as F-024					
F-027	PID type	0	1	1	-	○
	0: common PID 1: fast PID					
F-028	VMPPT voltage upper limit	250	Type Dependent	800	V	○
	220V: 310.0V 380V: 540.0V					
F-029	VMPPT voltage lower limit	250	Type Dependent	800	V	○
	220V type: 250.0V 380V type: 450.0V					
F-030	MPPT initial voltage	50	85	100	%	○
F-031	PV open-circuit voltage	200.0	Type Dependent	800.0	V	○
F-032	Weak light sleep frequency	F-002	30.00	F-001	Hz	○
	When the output frequency is less than or equal to this parameter value, the delay timer starts, after the timer reaches F-033 value when keeping in weak light status, the inverter enters sleep mode.					
F-033	Weak light sleep delay time	5.0	120.0	1200.0	s	○
	Weak light sleep delay time setting. When the output frequency is less than or equal to F-032 value, the delay timer starts. After the timer reaches this parameter value when keeping in weak light status, the inverter enters sleep mode. If the weak light is discontinuous, the delay timer will be cleared automatically.					
F-034	Weak light recovery voltage	250.0	Type Dependent	800.0	V	○
F-035	Weak light restart time	5.0	300.0	3600.0	s	○
F-036	Water shortage detection time	5.0	120.0	1200.0	s	○
	The interval between water pump shortage and alarm detection.					
F-037	Water shortage detection frequency	0.00	45.00	F-001	Hz	○
	When the output frequency reaches this parameter value, and the current is less than F-038					

Parameter	Description	Minimum Value	Default Value	Maximum Value	Unit	Change Permission
	value, inverter trips A52 water shortage fault.					
F-038	Water shortage detection current	0	40	200	%	○
	Percentage of the motor rated current. The inverter trips Err52 water shortage fault if the output current is less than this parameter.					
F-039	Water shortage restart time	1	20	2000	Min	○
	The inverter restarts automatically after the time set by this parameter after the water shortage fault.					
F-040	DI terminal logic	00000	00000	11111	-	◎
	0: High level active 1: Low level active Five digits can only be set as 0 or 1 for each digit, corresponding to the valid mode of DI1~5, respectively, they are: Ones digit: DI1; Tens digit: DI2; Hundreds digit: DI3; Thousands digit: DI4; Ten Thousands digit: DI5.					
F-041	DI1 terminal function selection	0	1	37	-	◎
	0: No function 1: Forward running FWD 2: Reverse running REV 3: Three-line operation control. 4: Three-line/Two-line switching. 5: Forward jog 6: Reverse jog 7: Fault reset 8: Multi-segment command terminal 1 9: Multi-segment command terminal 2 10: Multi-segment command terminal 3 11: External stop terminal, which is only valid for panel control. 12: Coast stop, that is, blocking PWM output. 13: External terminal shutdown (deceleration time 2, which is valid at any time) 14: Emergency stop 15: DC braking 16: Deceleration DC braking 17: External fault input (normally open) 18: External fault normally closed input 19: Running Command switch terminal 1 F-008=1 or 2 is effective. When F-008=1, this terminal can perform external terminal and keyboard key switching. When F-008=2, this terminal can perform communication and keyboard key switching. 20: Command source switching terminal 2 Used for switching between external terminal control and communication command control; If the current state is set to external terminal control, when this terminal is valid, switch to communication command control and vice versa. 21: Terminal UP 22: Terminal DOWN 23: UP/DOWN setting is cleared. 24: Frequency source switching 25: Switch between the main frequency source and the preset frequency.					

Parameter	Description	Minimum Value	Default Value	Maximum Value	Unit	Change Permission
	26: Switch between auxiliary frequency source and preset frequency. 27: Effective terminal for frequency setting. 28: Acceleration and deceleration are prohibited. 29: Acceleration and deceleration time selection terminal 1 30: PLC status reset 31: Speed control/torque control switching 4: Well water shortage. 32: Shortage water. 33: Well water full. 34: Second pressure setting. 35: Main frequency source switch to panel potentiometer. 36: Main frequency source switch to panel key. 37: Main frequency source switch to AI1.					
F-042	DI2 terminal function selection	0	2	37	-	⊙
	Functions are same as above.					
F-043	Terminal command mode	0	0	3	-	⊙
	0: Two lines mode 1 1: Two lines mode 2 2: Three lines mode 1 3: Three lines mode 2					
F-044	DO terminal logic	0000	00000	1111	-	○
	0: Positive logic. It is in valid state when the relay output terminal and the corresponding common terminal are connected and in invalid state when disconnected. 1: Negative logic. It is in valid state when the relay output terminal and the corresponding common terminal are disconnected and in invalid state when connected. Ones digit: RELAY1; Tens digit: RELAY2; Thousands digit: DO1; Ten Thousands digit: DO2.					
F-045	Relay 1 output function selection	0	1	15	-	○
	0: No function 1: Inverter running. When the inverter is in running status, the output frequency can be zero, the output is ON. 2: Fault output. When the inverter is in the faulty and stop status, the output is ON. 3: Ready to run. When the power supply of the inverter main circuit and the control circuit is stable, and there is no fault detected, and the inverter is ready to run, the output is ON. 4: Maximum frequency reached. When the operating frequency reaches the maximum frequency, the output is ON. 5: Minimum frequency reached. When the operating frequency reaches the minimum frequency, the output is ON. The signal is OFF when the inverter is stopped. 6: Maximum torque reached. When the inverter is in speed control mode, if the output torque reaches the torque limit, the inverter is in stall protection status and output is ON. 7: Communication control. Relay output is controlled by Modbus RTU (RS485). 8: Motor overload alarm. Output is ON before the motor overload protection. 9: Inverter overload alarm. Output is ON at 10s before the inverter overload protection. 10: Timed time exceeded. When the running time of the inverter reaches the set timing time, it outputs the ON signal. 11: The frequency reaches 1. When the operating frequency of the inverter reaches the set value, it outputs the ON signal. 12: The frequency reaches 2. When the operating frequency of the inverter reaches the set					

Parameter	Description	Minimum Value	Default Value	Maximum Value	Unit	Change Permission
	value, it outputs the ON signal. 13: The current reaches 1. When the running current of the inverter reaches the set value, it outputs the ON signal. 14: The current reaches 2. When the running current of the inverter reaches the set value, the ON signal is output. 15: AI1 input exceeds the upper or lower limits.					
F-046	Relay 2 output function selection	0	02	15	-	○
	Adjust the threshold when the relay output function is set as 11 to 13					
F-047	Relay 1 output delay time	0.0	0.0	3600.0	s	○
	Set the delay time of relay 1 from the status change to the actual output change.					
F-048	10V terminal output voltage selection	0	1	2	-	○
	0: 5 V 1: 10 V 2: 24 V					
F-049	Analog input / output signal format	0000	0000	1122	-	◎
	0: 0-10V 1: 0-20mA 2: 4-20mA Ones digit: AI1 Tens digit: AI2 Hundreds digit: AO1 Thousands digit: AO2					
F-050	AI curve 1 gain	0	1.00	20.00	%	◎
	Signal gain of analog input 1, the maximum gain is 20 times. For example, using AI1 as the target frequency setting, F-049 is set to "0:0-10V", and this parameter is set to 200%; then a 5V input signal enables the inverter to run at the maximum frequency.					
F-051	AI curve 1 zero-bias coefficient	-10.00	0.00	10.00	V	◎
	The signal bias value of analog input 1, maximum + / -10V. For example, using AI1 as the target frequency setting, F-049 is set to "0:0-10V", this parameter is set to 2.0; then an 8V input signal will make inverter run at the maximum frequency. When F-049 is set to "1:0-20mA", the 10.0V indicates the offset 20mA. The other values also correspond linearly. Internal calculated value of AI1 = actual input * F-050 + F-051					
F-052	AI curve 2 gain	0	100	2000	%	◎
	The signal gain of analog input 2, the maximum gain is 20.					
F-053	AI curve 2 zero-bias coefficient	-10.00	0.00	10.00	V	◎
	The signal offset value of analog input 2, the maximum offset is + / -10V.					
F-054	AO function selection	0	0	6	-	○
	The AO terminal of the inverter can provide 7 functions: 0: Running frequency. 1: (Target) Preset frequency. 2: Output current. The 100% AO output signal corresponds to 2 times the rated current. 3: Output torque. The 100% AO output signal corresponds to 2 times the rated torque. This value is the absolute value of the torque. 4: Output power. The 100% AO output signal corresponds to 2 times the rated power. 5: Output voltage. The 100% AO output signal corresponds to 1.2 times the rated voltage. 6: Communication control. The AO output signal is controlled by the Modbus RTU (RS485).					
F-055	AO1 gain	0	100	2000	%	○

Parameter	Description	Minimum Value	Default Value	Maximum Value	Unit	Change Permission
	The signal gain of analog output, the maximum gain is 20.					
F-056	AO1 zero-bias coefficient	-10.00	0.00	10.00	V	○
	The signal offset value of the analog output, the maximum offset is + / -10V.					
F-057	Device address	1	1	249	-	○
	Inverter address when using the communication function. If the value is set to 0, the host broadcast function is enabled.					
F-058	Baud rate	0	0	4	-	○
	0: 9600BPS					
	1: 19200BPS					
	2: 38400BPS					
	3: 57600BPS					
F-059	Data format	0	2	3	-	○
	0: No parity (8-N-2)					
	1: Even parity (8-E-1)					
	2: Odd parity (8-O-1)					
	3: No parity (8-N-1)					
F-060	Communication loss timeout	0	0	60	s	○
	Communication timeout detection is not enabled when the parameter is set to 0.0 seconds. When this parameter is set to 0.1 seconds or above, if the interval between current communication message and the next communication message exceeds the communication overtime time, the inverter will report a communication fault (Err16).					
F-061	Fault enable selection	0	01111	11111	-	○
	0: No protection					
	1: Enable protection					
	Ones digit: Motor overload protection selection					
	Tens digit: Output phase loss protection selection					
	Hundreds digit: Input phase loss protection selection					
Thousands digit: AI lower limit protection selection						
Ten thousands digit: Power-on time reached protection selection						
F-062	Fault auto-reset times	0	0	20	-	○
	When the inverter selects fault automatic reset, this parameter is used to set the number of times of automatically reset. After this number, inverter remains in fault state.					
F-063	Fault Auto-reset interval time	0.1	1.0	100.0	s	○
	Waiting time between inverter fault alarm and fault auto-reset.					
F-064	Factory parameter default	0	0	65535	-	◎
	1: Restore factory parameters					
	2: Clear record information					
F-065	User password	00000	00000	65535	-	○
	The inverter provides the user password protection function. When F-065 is set to non-zero, it is used as user password, and exiting function code editing state will enable the password protection. Press the SET key again to display "- - - -", and only input the correct user password to enter the parameter interface. To cancel password protection, only entering the correct password and set this parameter to 0.					
	Please remember this parameter value if password protection is enable!					
F-066	Display menu type	1	3	3	-	◎
	1: General menu.					
2: Only display modify parameters.						

Parameter	Description	Minimum Value	Default Value	Maximum Value	Unit	Change Permission
	3: Solar menu.					
F-067	Main display information switching	0	1	1	-	○
	0: Disable. When the display is switched from the frequency interface to other interfaces, automatic switching back to the frequency interface is prohibited. 1: Enable. When the display is switched from the frequency interface to other interfaces, it will automatically switch back to the frequency interface after 10 seconds.					
F-068	Reserved					
F-069	MPPT adjust period	0.1	5.0	3600.0	s	○
	Cycle time regulated by MPPT					
F-070	MPPT adjust step	1.0	3.0	100.0	v	○
	Voltage value regulated by MPPT every time.					
F-071	MPPT voltage range	1.0	20.0	100.0	v	○
	Range of MPPT voltage regulation.					
F-072	Undervoltage point	80.0	350.0	420.0	V	○
F-073	Overvoltage point	200.0	780.0	810.0	V	◎
F-074	Voltage sag function selection	0	1	2	-	◎
	0: Invalid 1: Deceleration. When the voltage of the inverter decreases suddenly (including but not limited to instantaneous power failure), the inverter decelerates. When the line voltage returns to normal and the duration exceeds F-076, the inverter accelerates to the original set frequency normally. 2: Ramp to stop. When the voltage of the inverter decreases suddenly (including but not limited to instantaneous power failure), the inverter ramps to stop. When the voltage of the inverter decreases suddenly (including but not limited to instantaneous power failure), and when the busbar voltage drops below F-077, the inverter reduces the output frequency, so that the motor is in the state of generating power. This function can make the electric energy that feeds back to the busbar voltage maintain the busbar voltage at about F-077, so that the system can normally decelerate to 0Hz. When the bus voltage returns to F-075 and the duration exceeds F-076, the inverter accelerates to the original setting frequency normally.					
F-075	Voltage sag judging voltage	80	85	100	%	◎
F-076	Voltage sag recovery judging time	0.0	0.5	100.0	s	◎
F-077	Voltage sag action judging voltage	60	70	100	%	○
F-078	Voltage sag gain Kp	0	40	100	-	○
F-079	Voltage sag integral coefficient Ki	0	30	100	-	○
F-080	Voltage sag action deceleration time	0.0	20.0	300.0	s	◎

5.2. Common Function Parameters

This product has monitoring parameters starting from U-000, they can only be accessed, cannot be modified. To access monitoring parameters, enter parameter F-000 first.

Function code	Explain	Units
U-000	Inverter running state.1: Forward 2: Reverse 3: Stop	-
U-001	Fault code	-
U-002	Set frequency	Hz
U-003	Operating frequency	Hz
U-004	Running speed	Rpm
U-005	Output voltage	V
U-006	Output current	A
U-007	Output power	KW
U-008	Busbar voltage	V
U-009	Output torque	Nm
U-010	Power factor Angle	-
U-011	DI input state. The default display ---- ,The effective values of DI1 , DI2 are ----↑, ----↑,respectively.	-
U-012	DO output state. The default display ---- , The effective values of RELAY1 is ----↑.	-
U-013	AI1simulation input value	V
U-014	AI2 simulation input value	V
U-015	AI1 voltage	V
U-016	AI2 voltage	V
U-017	PID setpoint	-
U-018	PID feedback	-
U-019	Remaining running time	Min
U-020	Current power on time	Min
U-021	Current running time	Min
U-022	Total running time	Hour
U-023	Total power-on time	Hour
U-024	Accumulated power consumption	kwh
U-025	Motor temperature value	°C
U-026	IGBT temperature value	°C
U-027	Actual switching frequency	kHz
U-028	True M-axis current value	A
U-029	True T-axis current value	A
U-030	Real value of feedback speed	Hz
U-031	MPPT trace voltage	V
U-031~U-041 Reserved		
U-042	Product serial number 16 bits lower	-
U-043	Product serial number 16 bits higher	-
U-044	Motor Boot version number	-
U-045	The type of CPU	-
U-046	Hardware version of the power board	-
U-047	Power board software version	-
U-048	Software version number of the control board	-

Function code	Explain	Units
U-049	Product number	-
U-050	Plant code	-
U-051	Type of the third(latest)fault	-
U-052	Type of the second fault	-
U-053	Type of the first fault	-
U-054	Frequency of the third fault	Hz
U-055	Current at third fault	A
U-056	Bus voltage of the third fault	V
U-057	Heatsink temperature at third fault	°C
U-058	Time of the third fault (time from this power-on)	Min
U-059	Time of the third fault (time from runtime)	Hour
U-060	Frequency of the second fault	Hz
U-061	Current at second fault	A
U-062	Bus voltage of the second fault	V
U-063	Heatsink temperature at second fault	°C
U-064	Time of the second fault (time from this power-on)	Min
U-065	Time of the second fault (time from runtime)	Hour
U-066	Frequency of the first fault	Hz
U-067	Current at first fault	A
U-068	Bus voltage of the first fault	V
U-069	Heatsink temperature at first fault	°C
U-070	Time of the first fault (time from this power-on)	Min
U-071	Time of the first fault (time from runtime)	Hour

6. Fault Diagnosis and Solution

After the fault occurs, the processing steps are as follows:

1. When the inverter fails, please confirm whether the keyboard display is abnormal? If yes, please consult our office.
2. If there is no abnormality, please check the following function codes, confirm the corresponding fault record parameters, and determine the true state when the current fault occurs through all parameters;
3. Check the table below and check whether there is any corresponding abnormal state according to the specific countermeasures.
4. Troubleshooting or asking for help from relevant personnel;
5. After confirming the troubleshooting, reset the fault and start the operation.

6.1. Error and Solutions of Solar Pump Inverter

Fault Name	Display	Possible Causes	Solutions
Inverter unit protection	Err01	<ol style="list-style-type: none"> 1. The output circuit is grounded or short circuited 2. The connecting cable of the motor is too long 3. The module overheats 4. The internal connections become loose 5. The main control board is faulty 6. The drive board is faulty 7. The inverter module is faulty 	<ol style="list-style-type: none"> 1. Eliminate external faults 2. Install a reactor or an output filter 3. Check the air filter and the cooling fan 4. Connect all cables properly 5. Contact for Technical support 6. Contact for Technical support 7. Contact for Technical support
Over current during acceleration	Err02	<ol style="list-style-type: none"> 1. The output is grounded or short circuited 2. The acceleration time is too short 3. Manual torque boost or V/F curve is not appropriate 4. The voltage is too low 5. The startup operation is performed on the rotating motor. 6. A sudden load is added during acceleration 7. The inverter power rating is too small. 	<ol style="list-style-type: none"> 1. Eliminate external faults 2. Increase the acceleration time 3. Adjust the manual torque boost or V/F curve 4. Adjust the voltage to normal range 5. Select rotational speed tracking restart or start the motor after it stops 6. Remove the added load. 7. Select a higher power rating inverter.
Over current during deceleration	Err03	<ol style="list-style-type: none"> 1. The output is grounded or short circuited 2. The deceleration time is too short 3. The voltage is too low 4. A sudden load is added during deceleration 5. The braking unit and braking resistor are not installed 	<ol style="list-style-type: none"> 1. Eliminate external faults 2. Increase the deceleration time 3. Adjust the voltage to normal range 4. Remove the added load. 5. Install the braking unit and braking resistor
Over current at	Err04	<ol style="list-style-type: none"> 1. The output is grounded or 	<ol style="list-style-type: none"> 1. Eliminate external faults

Fault Name	Display	Possible Causes	Solutions
constant speed		short circuited 2. The voltage is too low 3. A sudden load is added during deceleration 4. The inverter power rating is too small.	2. Adjust the voltage to normal range 3. Remove the added load. 4. Select a higher power rating inverter.
Over voltage during acceleration	Err05	1. The input voltage is too high 2. An external force drives the motor during acceleration 3. The acceleration time is too short 4. The braking unit and braking resistor are not installed	1. Adjust the voltage to normal range 2. Cancel the external force or install a braking resistor 3. Increase the acceleration time 4. Install the braking unit and braking resistor
Over voltage during deceleration	Err06	1. The input voltage is too high 2. An external force drives the motor during deceleration 3. The deceleration time is too short 4. The braking unit and braking resistor are not installed	1. Adjust the voltage to normal range 2. Cancel the external force or install a braking resistor 3. Increase the deceleration time 4. Install the braking unit and braking resistor
Over voltage at constant speed	Err07	1. The input voltage is too high 2. An external force drives the motor during running	1. Adjust the voltage to normal range 2. Cancel the external force or install a braking resistor
Control power supply fault	Err08	1. The input voltage is not within the allowable range	1. Adjust the voltage to normal range
Under voltage	Err09	1. Instantaneous power failure 2. The input voltage is not within the allowable range 3. The DC bus voltage is abnormal 4. The rectifier bridge and inrush resistor are faulty 5. The drive board is faulty 6. The control board is faulty	1. Reset the fault 2. Adjust the voltage to normal range 3. Contact for Technical support 4. Contact for Technical support 5. Contact for Technical support 6. Contact for Technical support
Inverter overload	Err10	1. The load is too heavy or locked-rotor occurs on the motor 2. The inverter power rating is too small.	1. Reduce the load and check the motor and mechanical condition. 2. Select a higher power rating inverter.
Motor overload	Err11	1. F-014 is set improperly 2. The load is too heavy or locked-rotor occurs on the motor 3. The inverter power rating is too small.	1. Set F-014 correctly 2. Reduce the load and check the motor and mechanical condition 3. Select a higher power rating inverter.
Power input phase loss	Err12	1. The three-phase power input is abnormal 2. The drive board is faulty 3. The lightning board is faulty 4. The control board is faulty	1. Eliminate external faults 2. Contact for Technical support 3. Contact for Technical support 4. Contact for Technical support

Fault Name	Display	Possible Causes	Solutions
Power output phase loss	Err13	<ol style="list-style-type: none"> 1. The cable connecting the inverter and the motor is faulty 2. The three-phase outputs are unbalanced when the motor is running 3. The drive board is faulty 4. The module is faulty 	<ol style="list-style-type: none"> 1. Eliminate external faults 2. Check whether the motor three-phase winding is normal 3. Contact for Technical support 4. Contact for Technical support
Module overheat	Err14	<ol style="list-style-type: none"> 1. The ambient temperature is too high 2. The air filter is blocked 3. The fan is damaged 4. The thermally sensitive resistor of the module is damaged 5. The inverter module is damaged 	<ol style="list-style-type: none"> 1. Lower the ambient temperature 2. Clean the air filter 3. Replace the damaged fan 4. Replace the damaged thermally sensitive resistor 5. Replace the inverter module
External equipment fault	Err15	<ol style="list-style-type: none"> 1. External fault signal is input via DI 2. External fault signal is input via virtual I/O 	<ol style="list-style-type: none"> 1. Reset the operation 2. Reset the operation
Communication fault	Err16	<ol style="list-style-type: none"> 1. The host computer is in abnormal state 2. The communication cable is faulty 3. The communication parameters are set improperly 	<ol style="list-style-type: none"> 1. Check the cabling of host computer 2. Check the communication cabling 3. Set the communication parameters properly
Contactor fault	Err17	<ol style="list-style-type: none"> 1. The drive board and power supply are faulty 2. The contactors is faulty 	<ol style="list-style-type: none"> 1. Replace the faulty drive board or power supply board 2. Replace the faulty contactor
Current detection fault	Err18	<ol style="list-style-type: none"> 1. The HALL device is faulty 2. The drive board is faulty 	<ol style="list-style-type: none"> 1. Replace the faulty HALL device 2. Replace the faulty drive board
Motor auto-tuning fault	Err19	<ol style="list-style-type: none"> 1. The motor parameters are not set according to the nameplate 2. The motor auto-tuning times out 	<ol style="list-style-type: none"> 1. Set the motor parameters according to the nameplate properly 2. Check the cable between inverter and the motor
EEPROM write fault	Err21	<ol style="list-style-type: none"> 1. The EEPROM chip is damaged 	<ol style="list-style-type: none"> 1. Replace the main control board
Short circuit to ground	Err23	<ol style="list-style-type: none"> 1. The motor is short circuited to the ground 	<ol style="list-style-type: none"> 1. Replace the cable or motor
Accumulative running time reached	Err26	<ol style="list-style-type: none"> 1. The accumulative running time reaches the setting value 	<ol style="list-style-type: none"> 1. Clear the record through the parameter initialization function
Accumulative power-on time reached	Err29	<ol style="list-style-type: none"> 1. The accumulative power-on time reaches the setting value 	<ol style="list-style-type: none"> 1. Clear the record through the parameter initialization function
Pulse-by-pulse current limit fault	Err40	<ol style="list-style-type: none"> 1. The load is too heavy or locked-rotor occurs on the motor 2. The inverter power rating is too small. 	<ol style="list-style-type: none"> 1. Reduce the load and check the motor and mechanical condition 2. Select a higher power rating inverter.

Fault Name	Display	Possible Causes	Solutions
Motor switchover fault during running	Err41	1. Change the selection of the motor via terminal during running of the inverter.	1. Perform motor switchover after the inverter stops
Water shortage fault	A52	1. Whether the pressure sensor is damaged 2. Whether the parameter setting of the inverter is wrong 3. Whether the pipe network and motor are correct	1. Detection sensor 2. Check the parameter setting of the inverter 3. Check the motor and pipe network
Over pressure fault	Err53	1. Whether the pressure sensor is damaged	1. Check the pressure sensor
Weak light sleep	A54	According to parameter F-032~F-035 light weak sleep setting, light weak sleep is prompted	1.Light intensity is too low 2.Improper parameter setting

6.2. Common Faults and Solutions

SN	Fault	Possible Causes	Solutions
1	There is no display at power-on	<ol style="list-style-type: none"> 1. There is no power supply to the inverter or the power input to the inverter is too low. 2. The power supply of the switch on the drive board of the inverter is faulty 3. The rectifier bridge is damaged. 4. The inrush resistor is faulty. 5. The control board or the operation panel is faulty 6. The cable connecting the control board and the drive board and the operation panel breaks. 	<ol style="list-style-type: none"> 1. Check the power supply 2. Check the DC bus voltage 3. Unplug the 10-core ribbon cable again. 4. Seek service from manufacturers.
2	" Err23" is displayed at power-on	<ol style="list-style-type: none"> 1. The motor or the motor output cable is short circuited to the ground. 2. The inverter is damaged. 	<ol style="list-style-type: none"> 1. Measure the insulation of the motor and the output cable with a megger 2. Contact us for technical support
3	Err14 (Module overheat) fault is reported frequently	<ol style="list-style-type: none"> 1. The setting of switching frequency is too high. 2. The cooling fan is damaged or the air filter is blocked. 3. Components inside the inverter are damaged (thermocouple or other). 	<ol style="list-style-type: none"> 1. Reduce the switching frequency (F-020) 2. Replace the fan and clean the air filter 3. Contact us for technical support
4	The motor does not rotate after the inverter runs	<ol style="list-style-type: none"> 1. Check the motor and the motor cables. 2. The inverter parameters are set improperly (Motor parameters). 3. The cable between the drive board and the control board is in poor contact. 4. The drive board is faulty. 	<ol style="list-style-type: none"> 1. Ensure the cable between the inverter and the motor is normal 2. Replace the motor or clear mechanical faults 3. Check the re-set motor parameters 4. Contact us for technical support
5	The DI terminals are disabled	<ol style="list-style-type: none"> 1. The parameters are set incorrectly. 2. The external signal is incorrect. 3. The control board is faulty. 	<ol style="list-style-type: none"> 1. Check and reset the parameters (F-041, F-042). 2. Re-connect the external signal cables 3. Contact us for technical support

6	The inverter reports over current and over voltage frequently	<ol style="list-style-type: none"> 1. The motor parameters are set improperly. 2. The acceleration / deceleration time is improper. 3. The load fluctuates. 	<ol style="list-style-type: none"> 1. Re-set motor parameters or re-perform the motor auto-tuning 2. Set proper acceleration/deceleration time 3. Contact us for technical support
7	Err17 is reported upon power-on or running	The inrush contactor is not picked up.	<ol style="list-style-type: none"> 1. Check whether the contactor cable is loose 2. Check whether the contactor is faulty 3. Check whether 24V power supply of the contactor is faulty 4. Contact us for technical support

6.3. Maintenance Bond

- (1) Free warranty only refers to the inverter itself.
- (2) In case of failure or damage within the warranty terms, our company is responsible for 12 months warranty (from the date of delivery, the bar code on the fuselage shall prevail, and if there is a contract agreement, it shall be implemented according to the agreement). For more than 12 months, we will charge a reasonable maintenance fee;
- (3) During the warranty period, our company will charge a certain maintenance fee if:
 - a. Machine damage caused by the user's failure to comply with the regulations in the user manual;
 - b. Machine damage caused by mistakes in use and unauthorized maintenance and modification;
 - c. Damage caused by fire, flood, abnormal voltage, etc.;
 - d. Damage caused by using the inverter for abnormal functions;
 - e. Damage caused by man-made falling and transportation after purchase;
 - f. Failure and damage caused by obstacles outside the machine (such as external equipment factors);
- (4) The service fee is calculated according to the uniform standard of the manufacturer. If there is a contract, the contract will take precedence.
- (5) If there is any problem in the service process, please contact the supplier in time.
- (6) The final interpretation right of warranty instructions belongs to our company.

Warranty Card

Customer Information	Address:	
	Name:	Contact:
	Postal code:	Tel:
Product Information	Product model:	
	Fuselage Bar code (posted here):	
	Agent name:	
Fault Information		

Certificate

This product has gone through rigorous quality control tests at factory.

Inspector	
Approval Mark	